

Packet level performance evaluation of NG All-IP mobile networks

D. Moltchanov, {moltchan@cs.tut.fi}

Tampere University of Technology
Institute of Communication Engineering

What? [1/1]

The initial aims of the study were to:

- formalize QoS support in NG-All IP mobile networks;
- provide structured approach to performance evaluation of these networks.

As an outcome we expect to get classic IP layer performance parameters:

- Operator-oriented estimators:
 - Estimation of end-to-end packet level performance degradation:
 - * delay/loss parameters;
 - * usage-ready parameters: delay and loss quantiles etc.
 - Estimation of the best placement of transmitter antenna:
 - * based on loss/delay estimators.
- Vendor-oriented estimators:
 - requirements on buffer size of mobile terminals;
 - evaluation of error concealment techniques at the air interface.

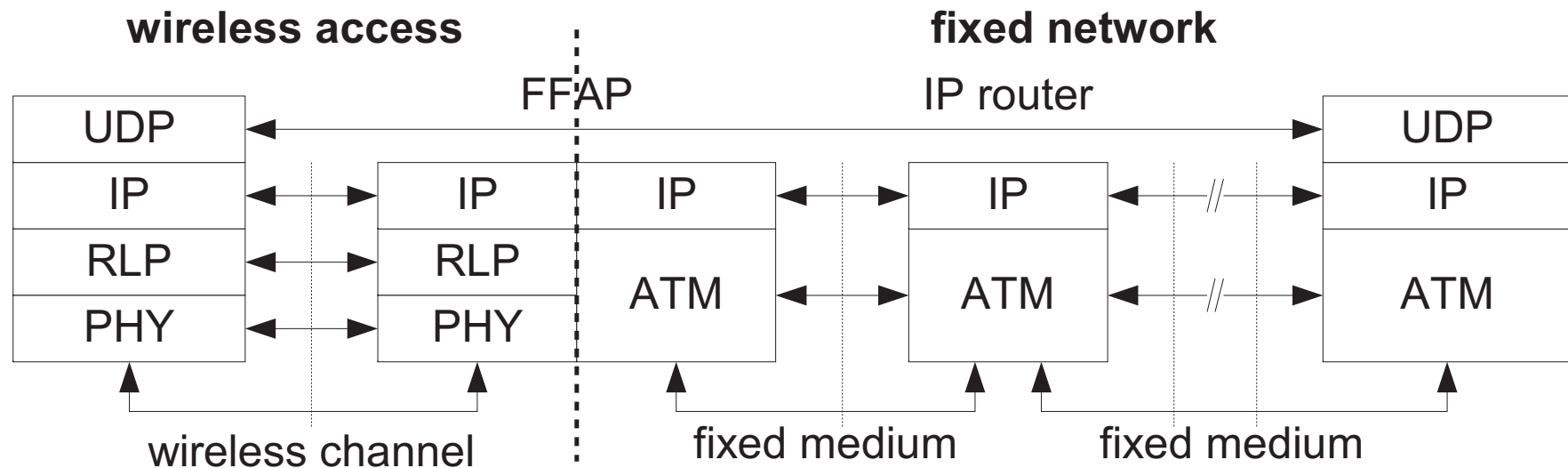

Figure 1: Expected end-to-end protocol configuration of NG All-IP systems.

To predict performance degradation:

- **in fixed networks:** packet forwarding procedures;
- **at the air interface:** bit errors of transmission medium.

Weak point: **air interface between MT and FFAP.**

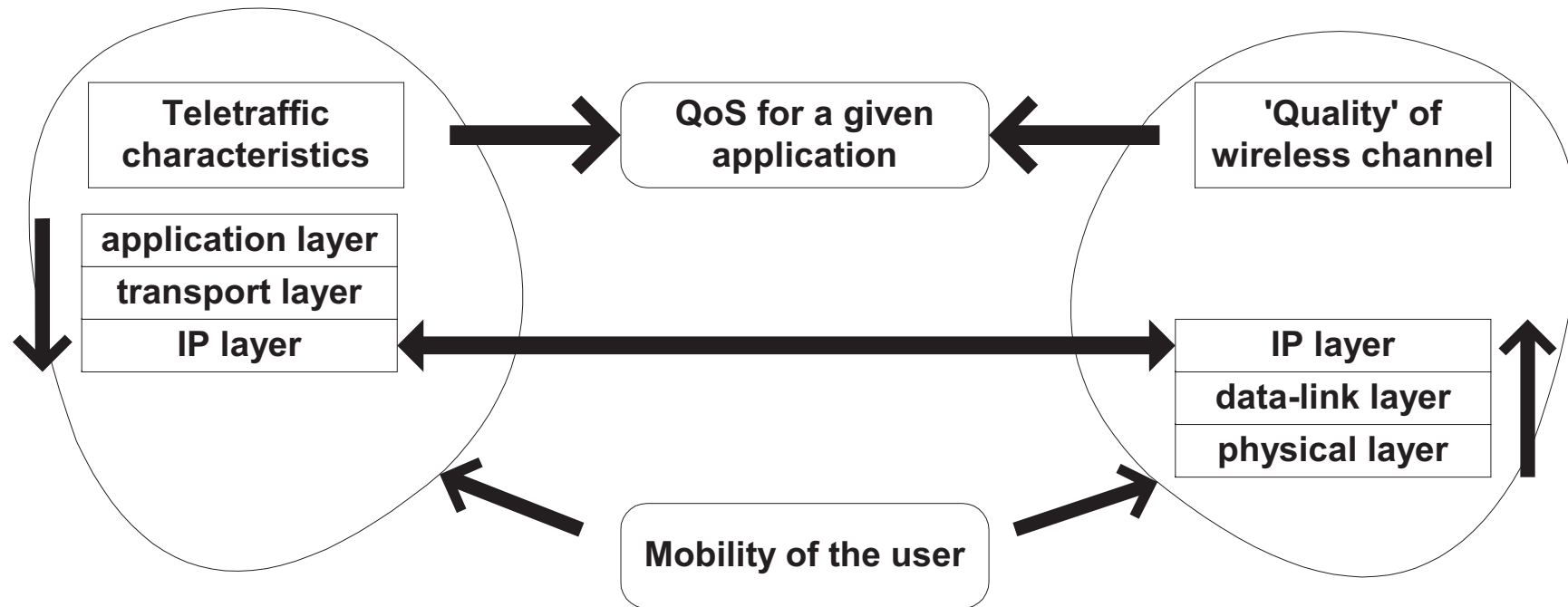
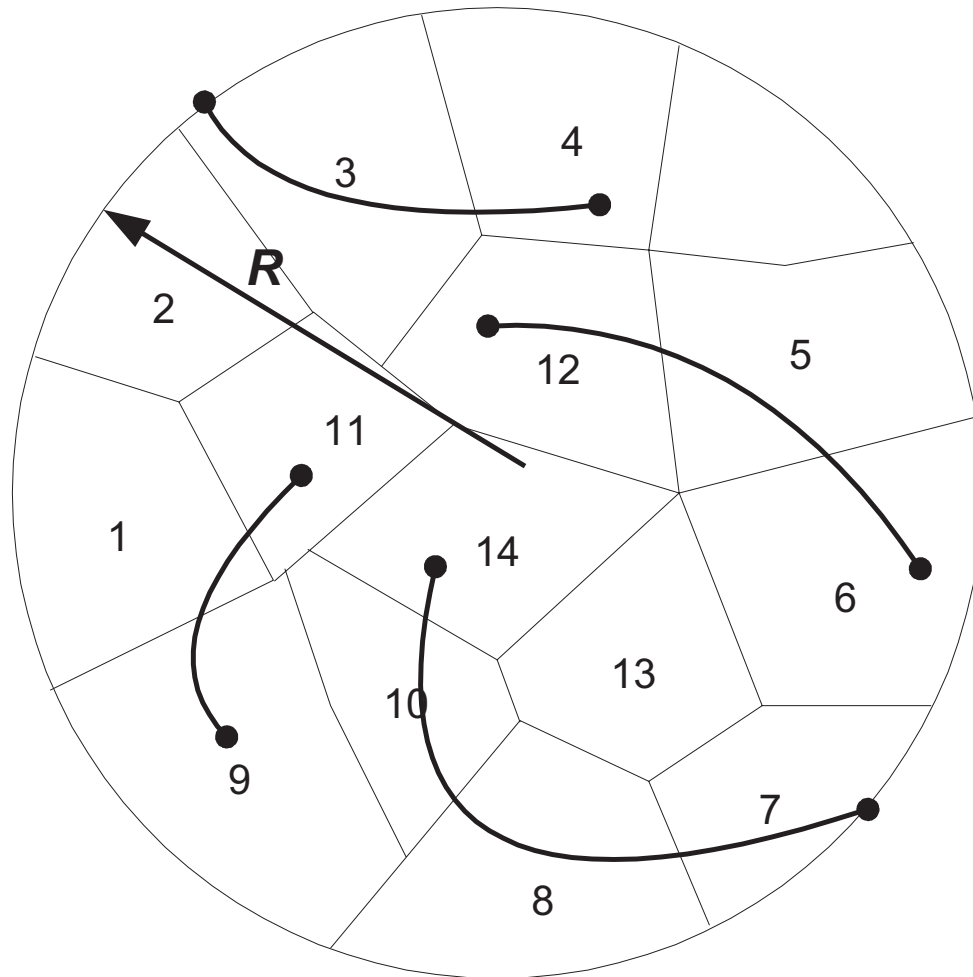

Figure 2: Components that define QoS at the air interface.

- mobility **strictly** influences wireless channel characteristics;
- mobility **may** influence teletraffic characteristics.



Large-scale propagation:
local average signal strength

Different areas have different local average signal strengths. Movement between them is due to mobility of the user.

Small-scale propagation:
rapid fluctuation of the signal strength

Different areas have different small-scale propagation characteristics. Movement between them is due to mobility of the user.

Figure 3: Influence of mobility on wireless channel characteristics.

Why? [4/4]

- Conventional 2G systems:
 - voice application dominated;
 - physiological tests: it requires 17% to acquire it.
- 3G/NG All-IP mobile systems:
 - all Internet applications should be transparently supported;
 - multimedia applications require to 97% of human attention to acquire it.
- All mobile systems (2G/3G/NG All-IP):
 - restrictions on using mobile phones when driving.

We may expect:

- sessions are shorter when user is on the move;
- session initiation rate is lower when user is on the move.

Such influence is probabilistic in nature.

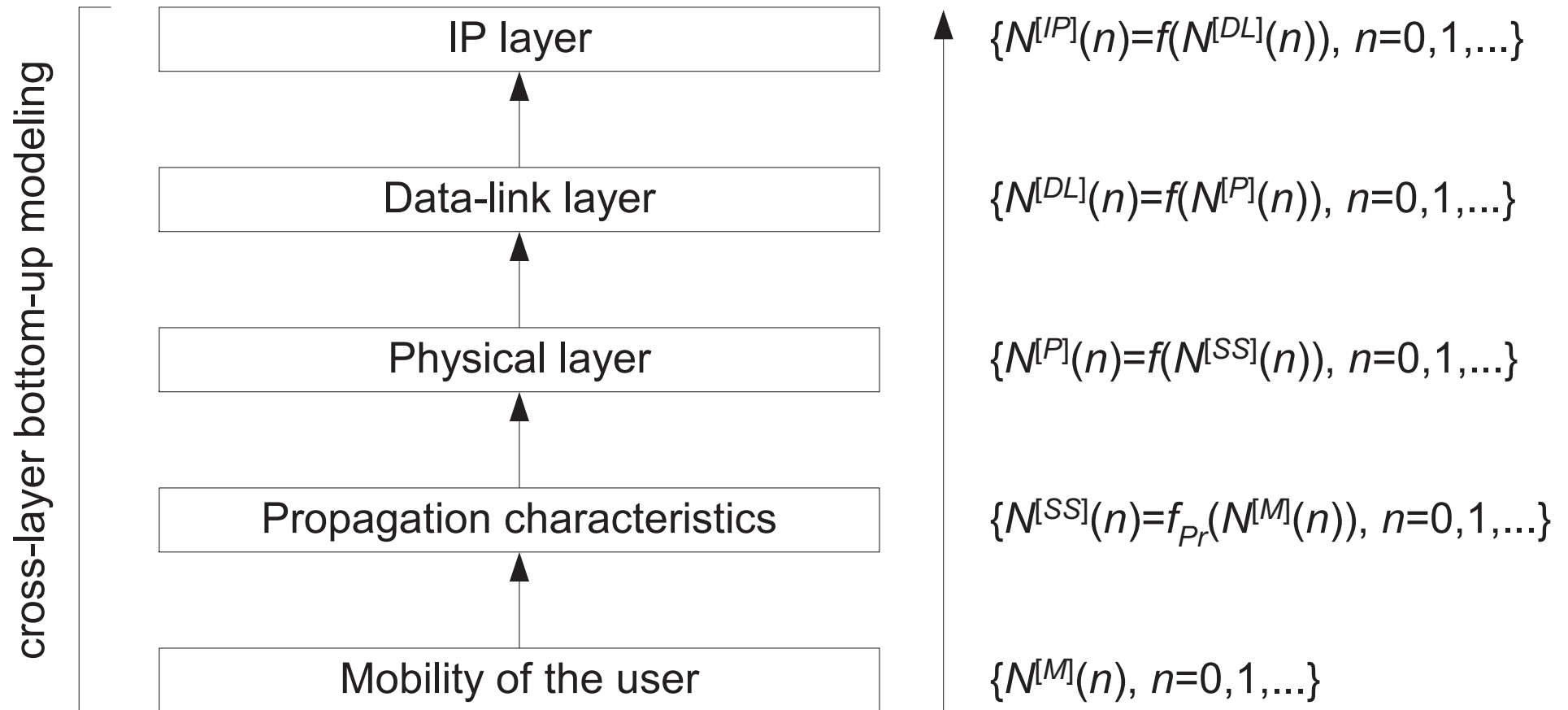

Figure 4: Structure of the wireless channel model.

How: wireless channel [2/3]

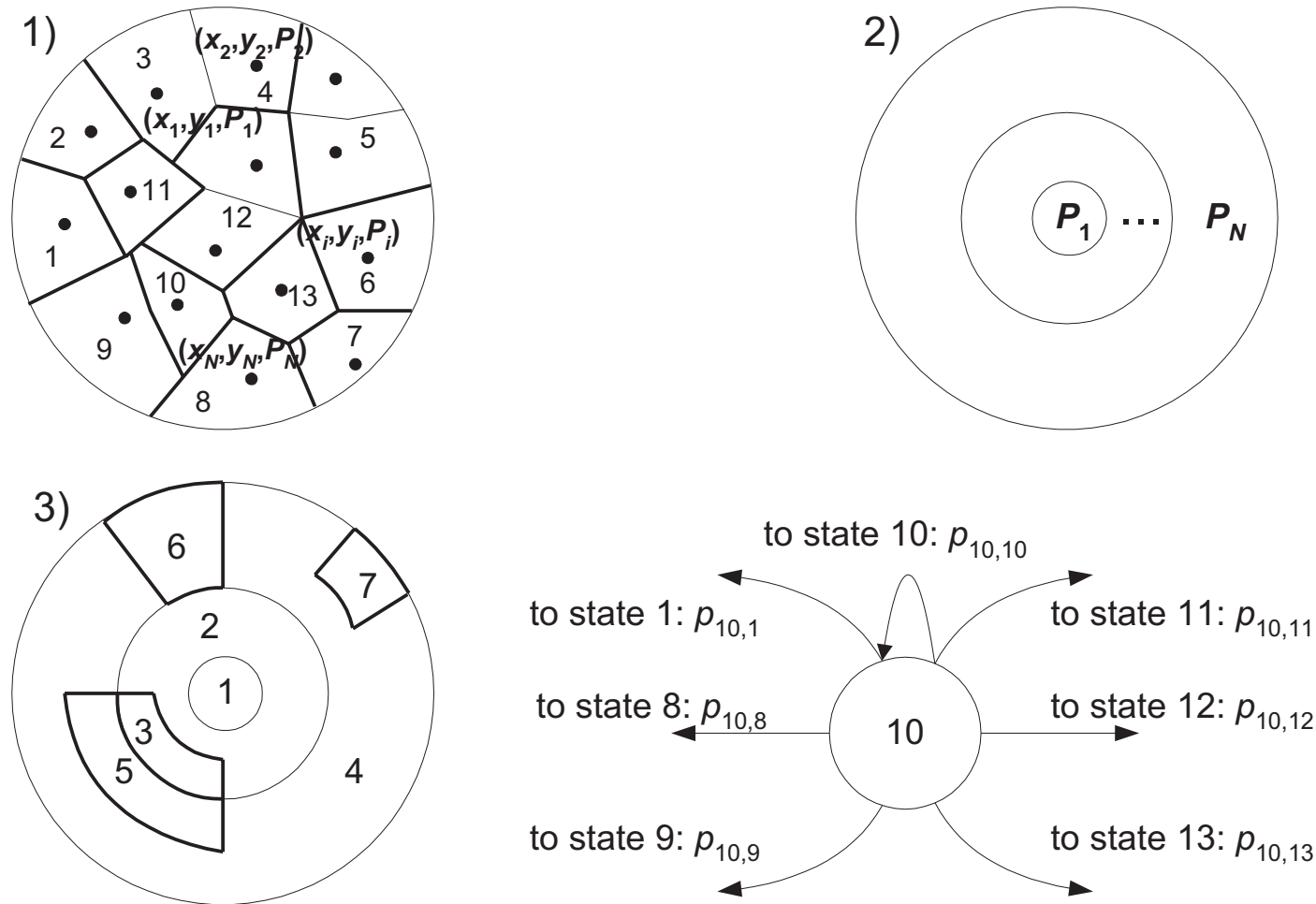

Figure 5: Capturing propagation characteristics of wireless channel.

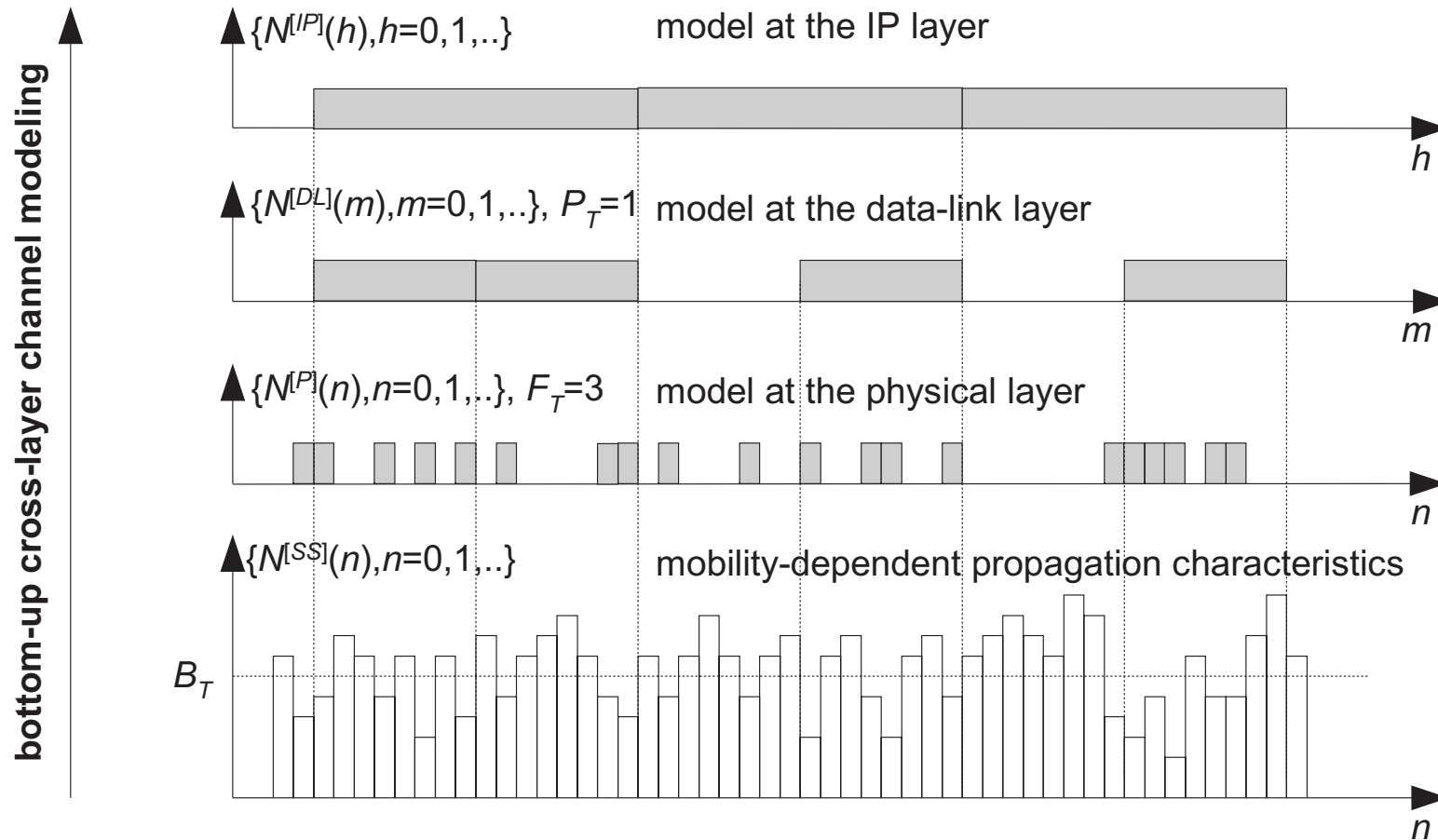

Figure 6: Example of wireless channel model at the IP layer.

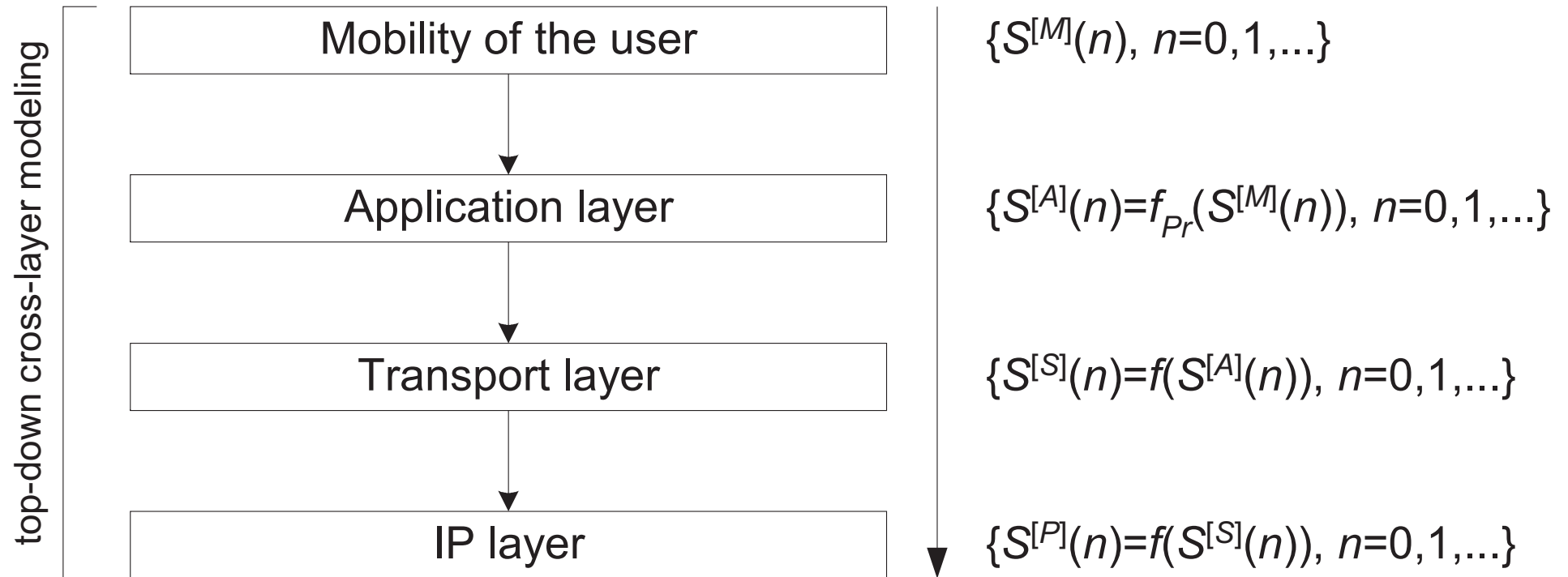

Figure 7: Structure of the teletraffic model for NG All-IP networks.

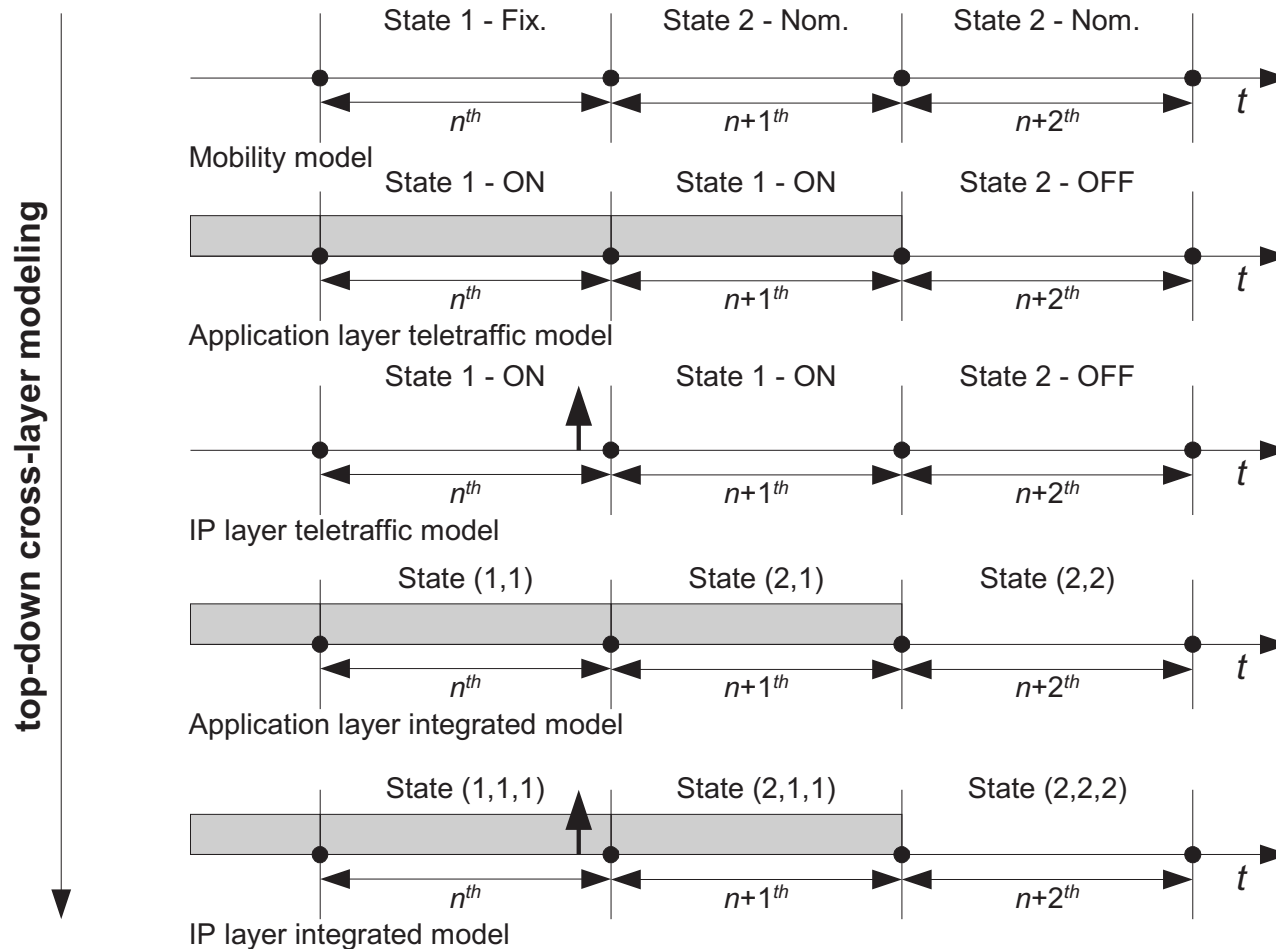

Figure 8: Example of the teletraffic model at the IP layer.

How: performance evaluation

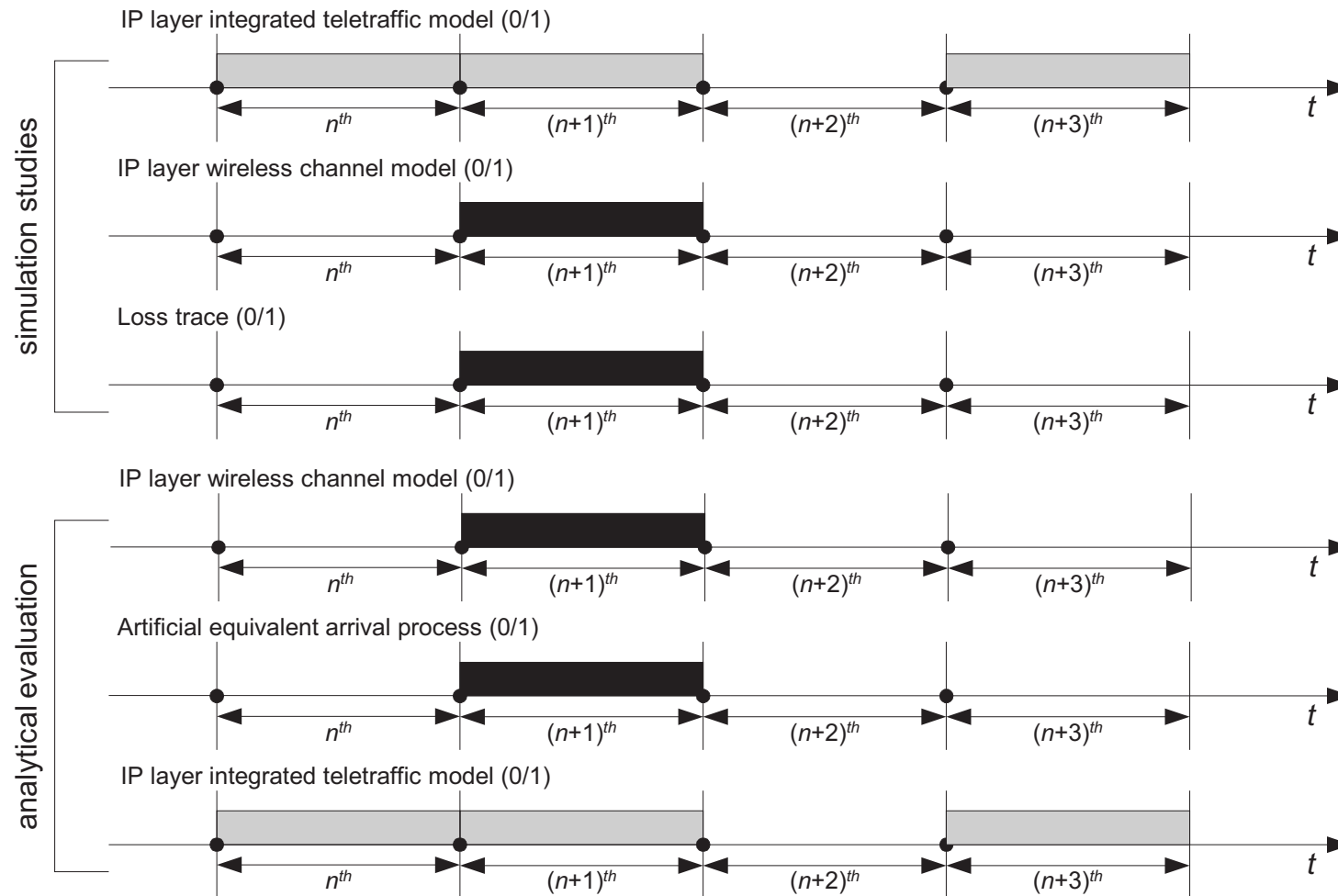

Figure 9: Usage of the proposed approach.

Conclusions

Analysis:

- simulation is straightforward;
- mathematical analysis is possible.

Wireless channel model:

- +: explicitly includes mobility behavior of the user;
- +: reflects cross- and auto correlational properties;
- +: has a bottom-up cross-layer modular structure.

Teletraffic model:

- +: explicitly includes mobility behavior of the user;
- +: reflects cross- and auto correlational properties;
- +: has a top-down cross-layer modular structure.