



Tampere University of Technology
Institute of Communications Engineering

ICEFIN Workshop 2004
“Advances in Wired/Wireless Networking”

Network Planning Aspects for
3G/4G Wireless Networks

Andrey Krendzel

krendzel@cs.tut.fi



Outline

- Scope of the Research

Core Network Planning Aspects for 3G Networks

Radio Access Network Planning Aspects for 4G Networks

- Objective of the Research
 - Structure of the Research
 - Results of the Research
-



Core Network Planning Aspects for 3G Networks

Global evolution process in wireless communications



Large diversity of 3G services



Dramatic quantitative and qualitative changes
in parameters and nature of data traffic

(increase in the rate of transactions and in the total traffic intensity;
self-similarity)



3G Network Planning Problems



Core Network Planning Aspects for 3G Networks

3G Network Planning Problems

- the estimation problem of prospective 3G users;
 - the prediction problem of data traffic characteristics;
 - the problem of the performance evaluation of IM – subsystem elements taking into account the self-similar nature of the multiservice traffic
-



Radio Access Network Planning Aspects for 4G Networks

WIRELESS SYSTEMS	CORE NETWORK DOMAINS
2G	CS CN
2G phase 2 +	CS CN and PS CN
3G (UMTS Rel'3)	CS CN and PS CN (enhanced 2G phase 2+ CN)
3G (UMTS Rel'4)	CS CN, PS CN, IM CN
3G (UMTS Rel'5,6)	IM CN
4G	IM CN (enhanced 3G CN)

The major changes are in the 4G RAN



Radio Access Network Planning Aspects for 4G Networks

The Forth Generation (4G) systems

- significantly higher bit rate than 2 Mb/s (100 Mb/s as maximum),
 - high capacity with a low bit cost,
- supporting all type of telecommunication services from the viewpoint of multimedia communication.



Changes in the 4G RAN

- BS radius cell is supposed to be shorter;
- the 4G RAN will comprise more BSs;
- more frequent handover will occur resulting in a heavy load on the links between RNC and BSs



Changes in the 4G RAN architecture



Radio Access Network Planning Aspects for 4G Networks

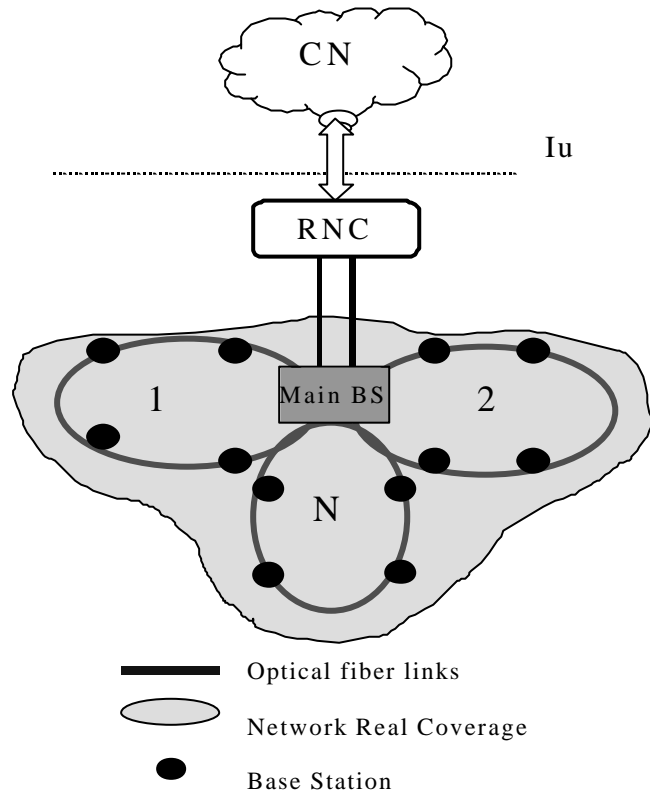

RNC –Radio Network Controller
CN – Core Network
Iu – interface between RNC and CN Domains

4G RAN Planning Problems

1. Ring topology estimating with respect to cost and reliability and comparing its with other ones.



Radio Access Network Planning Aspects for 4G Networks

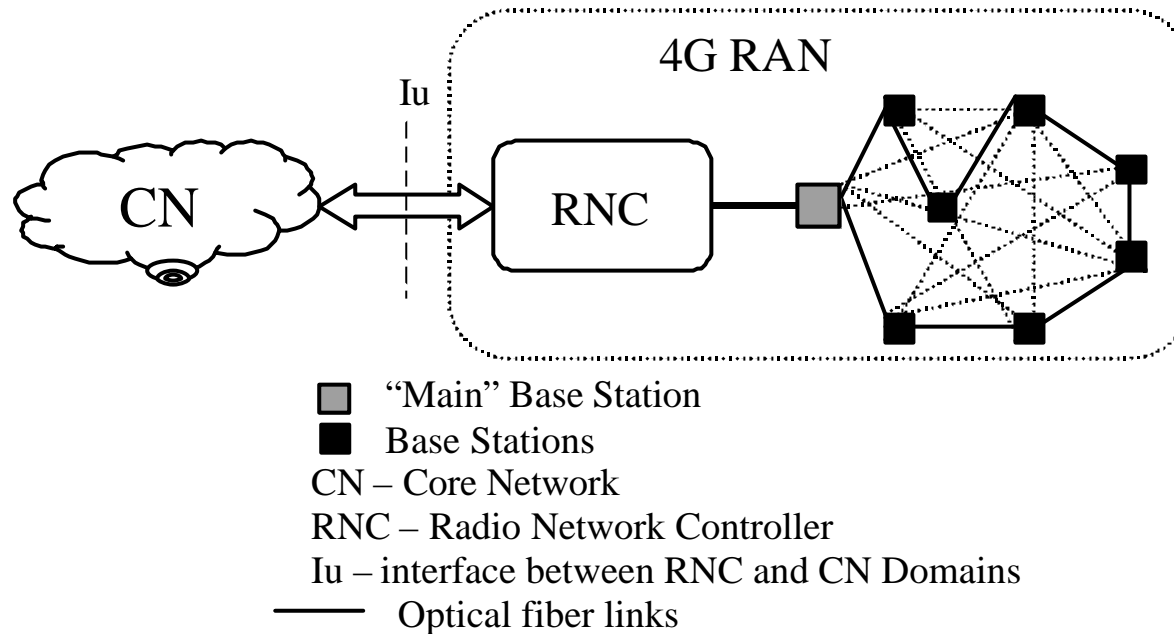

4G RAN Planning Problems

2. The problem of the minimum-cost configuration of physical links between BSs in the 4G RAN ring topology
-



Objective of the Research

The main objective of the research is to develop solution methods for the above-mentioned problems. It will enable planning 3G/4G networks in such a way that both technical and economical advantages can be achieved when constructing and exploiting the networks.



Structure of the Research

Solution Methods for 3G Network Planning Problems

1. The method for estimating a number of prospective 3G users
2. The estimation method for data traffic generated by 3G users

The following parameters of the data traffic are estimated:

- the specific (per user) rate of transactions in a busy hour,
 - the average duration of 3G calls,
 - the specific (per user) traffic intensity created by 3G calls in a busy hour,
 - the total traffic intensity on nodes of the IM - subsystem.
-



Structure of the Research

Solution Methods for 3G Network Planning Problems

3. The performance evaluation method for the IM - subsystem nodes taking into account the self-similar nature of the multiservice traffic (FBM/D/1/W queuing system is considered, where FBM is Fractional Brownian Motion).

The following probabilistic and time characteristics of nodes are determined:

- upper and lower bounds of the server service rate;
 - the average queue length in buffers;
 - the average service time of information units;
 - server utilization.
-



Structure of the Research

Solution Methods for 4G RAN Planning Problems

1. The method for a quantitative estimation of reliability and cost parameters of different Radio Access Network topologies. The parameters of one ring topology, multi-ring topologies and a radial one are considered and compared to each other.
 2. The method for physical links ring configuration between 4G Radio Access Network elements with a minimal deployment cost.
-



Results of the Research

- ✓ The results of the research allow establishing both
the requirements to equipment of internal IP-networks such as throughput of channels, performance of nodes and routers in the 3G/4G systems,
and
the requirements to equipment of gateways providing the interaction between 3G/4G systems and external networks.
 - ✓ It gives making easier both *the preparation of business-plans for development of wide range of 3G/4G services and the preparation of system projects for deployment of PS CN domains, and, afterwards, IM-subsystems .*
-



Results of the Research

✓ Some recommendations on using different topologies of physical links in the RAN for mobile communication systems beyond IMT-2000 from the viewpoint of cost and reliability are developed.

✓ Results of the research enable also to minimize expenses when the 4G RAN deployment.

The obtained methods of effective 3G/4G planning may be considered as a basis for software creating in order to automate the planning process.
